

# BATCH CONTROLLER (PANEL TYPE)

## Model 414



### Overview

The 414 Batch Controller is suited to flow applications where precise measurement and control of batch quantities is required. Batch total, flow rate, accumulated total and preset value can all be displayed in engineering units on the large LCD display.

The 414 will interface to most flowmeters with versions available for pulse and analog inputs.

### Batch Features

#### Automatic Overrun Compensation

Based on previous batches, the 414 will automatically compensate for any overrun which may be caused by slow closing valves.

#### Batch Limit

A maximum batch quantity can be programmed during set-up, so that the operator cannot enter a batch size that exceeds this limit.

#### Signal Time-out

If the flow signal cuts out midway through a batch, the output relays are de-energised, and an alarm signalled via an open collector output.

#### Remote Start / Stop

Remote push-button switches can be connected to the rear terminal strip, to start and stop batches.

#### Auto Restart

The 414 can be programmed to automatically restart the batch after a preset time delay.

#### Count Up / Down

The instrument can be programmed to count up from zero, or to count down from the batch quantity.

#### End of Batch

An End of Batch signal is provided via an open collector transistor output.

### Models Available

#### Model 414A

Analog input version with both linear and square law input relationships.

#### Model 414B

Frequency input version that will accept pulse and open collector inputs from opto-sensors or Hall effect devices.

#### Model 414D

Frequency input version with an input conditioning card capable of accepting mV signals from coils, 2-wire proximity sensors, reed switch inputs and most other pulse type signals.

#### Model 414H

For applications where batches are very short (< 15 seconds) the 414H features a response time of less than 20ms.

The input is identical to the 414D but the scaling factor is limited to 4000 and the input frequency range is limited to 8kHz.

#### Model 414Q

Quadrature input version where the flowmeter produces two pulse or square wave signals 90° out of phase. Through the phasing of signals, forward and reverse flow can be detected.

#### Model 414LA

4-20 mA temperature input version with temperature correction for general chemicals, petroleum to API tables and LPG (see separate data sheet).

#### Model 414LR

RTD temperature input version with temperature correction for general chemicals, petroleum to API tables and LPG (see separate data sheet).

### Operation

Four key switches on the front fascia, enable the batch quantity to be set, and batch operations to be started, stopped or reset.

To set a batch quantity, the BATCH SET key is pressed, and then the ▷ and △ keys can be used to change and increment digits. Once set, the BATCH SET key is again pressed to return to Run mode.

Keypad operations are straight forward and four LED's indicate the operational status at all times.

In Run mode, the DISPLAY key can be used to display flow rate, batch and accumulated total.

The unique four key function simplifies operation, making the instrument suited to use by operators with minimal training.

### Versatile Performance Options

The instrument will operate from 12 to 28V dc or from 100/110/220V ac mains.

The fascia is fully watertight to IP65 (Nema 4X) and is resistant to most chemicals.

The standard instrument is supplied as panel mount. Field enclosures and explosionproof enclosures are optionally available.

### Computer / Printer Interface

An RS232 and RS422 / 485 option is available for interfacing to computers and printers. The interface allows the Batch Controller to be fully controlled from a computer via an ASCII protocol.

Software drivers are included for a number of printers and can print a ticket with time and date, a sequential delivery / batch number and the batch and accumulated totals. An optional header for the ticket can also be printed.

### One or Two Stage Valve Control

Two output relays provide control for single or dual stage valve operation. The first relay will energise at the start of the batch, and de-energise when the batch is complete.

The second relay can be programmed to energise at a set time after the start, and to de-energise at a set quantity prior to completion of the batch.

This feature enables a slow startup and slow shutdown of the flow.

The Batch Controller can also be programmed to count up from zero or down from the Batch quantity.

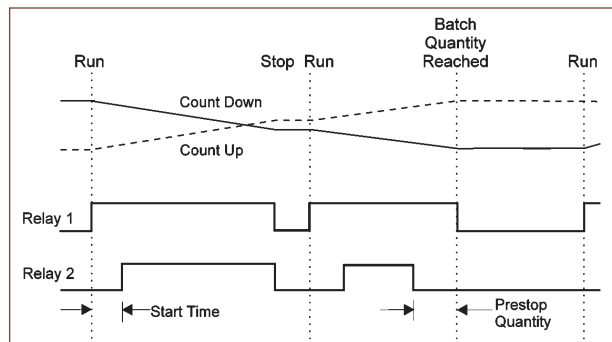

# BATCH CONTROLLER (PANEL TYPE)

## Specifications Model 414

### General

<b>Display</b>	6 digit 0.7" (17.8mm) high LCD
<b>Display Update Rate</b>	0.25s
<b>Data Retention</b>	All set-up parameters and totals are stored in a non-volatile memory with 10 years retention
<b>Pulse Output</b>	Open collector output with a 10ms pulse produced on each increment of the accumulated total
<b>Max Output</b>	49 pulses per second
<b>Max Current</b>	100 mA
<b>Transducer Supply</b>	8-24V dc field adjustable, 50 mA maximum.
<b>Relays</b>	
<b>Max Power</b>	1250VA.
<b>Max Voltage</b>	250V ac, 30V dc.
<b>Max Current</b>	5 Amps.
<b>Power Requirements</b>	
<b>DC Supply</b>	11.5-28.5V dc, 200 mA typical current (no options).
<b>AC Supply</b>	AC mains set internally to 95-135V ac or 190-260V ac.
<b>Operating Temperature</b>	0 to 55°C.

### Approvals

<b>Electrical</b>	ETL (US) approved to UL 508 and CSA
<b>Interference</b>	CE Compliance
<b>Enclosures</b>	CENELEC, FM, CSA and SAA approved enclosures available for hazardous areas

### Frequency Input Models

<b>Frequency Range</b>	
Minimum	0.25Hz on Rate, 0Hz on Total
Maximum	10kHz (except 414H which is 8kHz)
<b>Scaling Range</b>	
	0.1000 to 50,000
	0.1000 to 4,000 (414 H)

### Analog Input (Model 414A)

<b>Inputs</b>	Isolated 4-20 mA, 0-20 mA & 0-10V
<b>Input Impedance</b>	
Current	250 ohms
Voltage	10K ohms
<b>Accuracy</b>	0.075%
<b>Span</b>	0.1000 to 50,000
<b>Cutoff Point</b>	A low flow rate cutoff can be programmed below which flow is not registered The cutoff is programmed as a percentage of span
<b>Relationship</b>	Linear, square root or programmable power between 0 and 9.99

### Optional Enclosures

<b>Field Enclosures</b>	IP65 (Nema 4X)
<b>Explosionproof Enclosures</b>	

Important: Specifications are subject to change without notice.

### Dimension Drawings

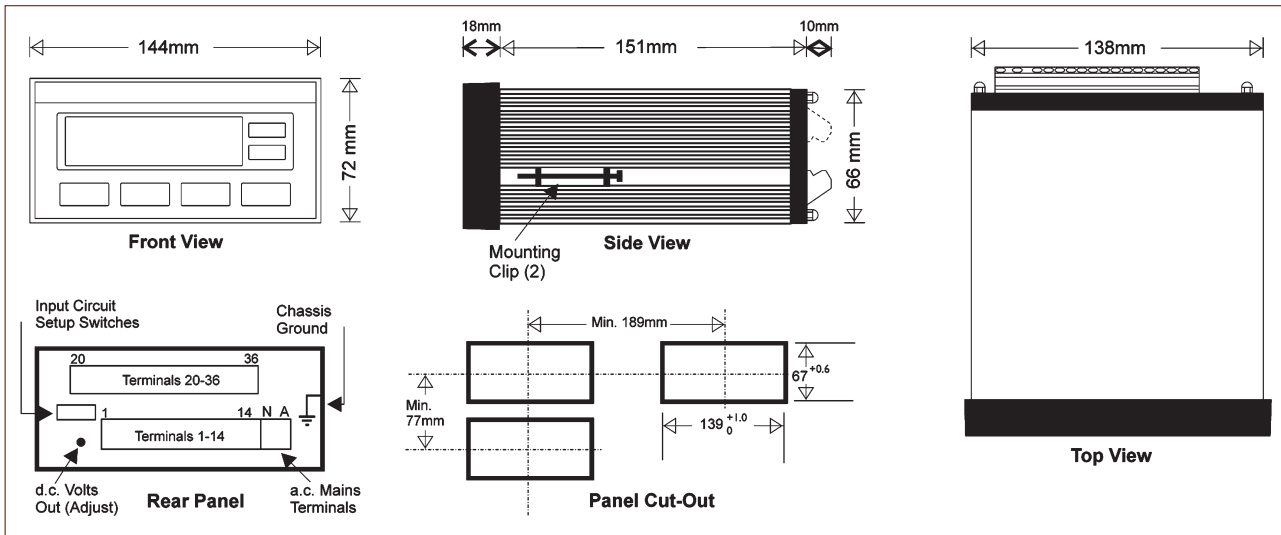

# BATCH CONTROLLER (PANEL TYPE)

## Terminal Descriptions Model 414

Terminals Common to all Models	
No.	
1	Calibration
2	Switch Common
11	DC Power Out
12	DC Ground
13	DC Power In
28	Remote Run Switch

No.	
29	Remote Stop Switch
30	End of Batch Signal
31	Relay 2 Normally Open
32	Relay 2 Normally Closed
33	Relay 2 Common
34	Relay 1 Normally Open
35	Relay 1 Normally Closed
36	Relay 1 Common

RS232/422 Option (All Models)	
No.	
20	RS232 Signal Ground
21	RS232 Data In
22	RS232 Data Out
23	RS422 (-) Data Out
24	RS422 (+) Data Out
25	RS422 (-) Data In
26	RS422 (+) Data In
27	RS232 CTS

## Terminals Specific to Each Model

No.	414A	414B	414D 414H	414LA	414LR	414Q	No.
3	Not Used	Not Used	Not Used	Flow Input Ch. 2	Flow Input Ch. 2	Flow Input Ch. 2	3
4	Display Switch	Not Used	Display Switch	Not Used	PT100 (+)	Not Used	4
5	Batch Set Switch	Not Used	Batch Set Switch	Temp. (4-20mA)	PT100 Signal (+)	Not Used	5
6	Not Used	Not Used	Not Used	Not Used	PT100 Signal (-)	Not Used	6
7	Flow Alarm	Not Used	Flow Alarm	Flow Alarm	Flow Alarm	Flow Alarm	7
8	Flow Common	Flow Common	Flow Common	Flow Common	Flow Common	Flow Common	8
9	Flow Signal (mA)	Flow Signal	Flow Signal (mA)	Flow Input Ch. 1	Flow Input Ch. 1	Flow Input Ch. 1	9
10	Pulse Out	Not Used	Pulse Out	Pulse Out	Pulse Out	Pulse Out	10
14	Flow Signal (Volts)	Not Used	Not Used	Flow Input (4-20mA)	PT100(-)	Not Used	14

## Ordering Information

When specifying please indicate model(s) required using the following method.

414 D . 1 0 E 0

<p><b>Basic Model</b></p> <p><b>Type of Input</b></p> <p>Analog Input - A</p> <p>Pulse Input - B</p> <p>Pulse or frequency input with signal conditioner - D</p> <p>High speed response (pulse or frequency) - H</p> <p>Quadrature pulse - Q</p> <p>Temperature Compensation (4-20mA) - LA</p> <p>Temperature Compensation (RTD) - LR</p>	<p><b>Special Options</b></p> <p>0 - No option</p> <p>B - Backlighting</p> <p>C - Conformal Coating</p> <p><b>Power Supply</b></p> <p>E - 220-240V ac</p> <p>A - 110-120V ac</p> <p>D - 12-28V dc</p> <p>J - 100V ac</p> <p><b>Communications</b></p> <p>0 - No option</p> <p>2 - RS232/422</p> <p><b>Mounting Options</b></p> <p>1 - Panel mount</p> <p>N - Field mount enclosure</p> <p>3 - Explosionproof enclosure</p>	
---	--	--

## Model 220



### Overview

The Model 220 Level Monitor accepts a 4-20 mA signal from a wide range of level sensors, including pressure transmitters, ultrasonic sensors or capacitance probes, and displays both level and tank contents on a large LCD display.

Solid state relay outputs provide up to four level alarms and a 25 point non-linearity correction table allows the instrument to be programmed to fit most tanks.

The Level Monitor is powered entirely from the 4-20 mA current loop and, therefore, requires no external power or batteries.

The instrument is fully programmable with setup parameters such as span, offset, alarm levels, etc, stored in a non-volatile memory which will retain all data for more than 10 years without power.

The Model 220 is housed in an attractive IP67 (Nema 4X) polycarbonate enclosure which is completely watertight.

A wall mounting bracket is supplied as standard, while a 2 pipe mounting bracket is available as an option.

Alternatively, the Model 220 can be supplied as a panel mount instrument.

### Display

#### Level Bar Graph

Displays measured level as a percentage (0-100%).

#### Contents

7 digit numeric display of contents with programmable span. An offset can be programmed to account for contents remaining in the tank when the measured level is 0%.

The contents are displayed with 4 1/2 digit resolution so that larger values are displayed with trailing zeros (for example, 1437765 would be displayed as 1437700 and 5467289 would be displayed as 5467000).

#### Filter

A programmable filter will filter out fluctuations in readings caused by agitation in the tank.

#### Density

Density correction is provided for level devices which are density sensitive. Should the density change, a correction factor can be programmed via the front panel.

### Relays

#### Type

Four solid state opto-isolated DC relays arranged as high-high, high, low and low-low.

An optional DIN rail mounted relay module is available which incorporates mains operated relays.

#### Acknowledgment

Alarms can be programmed for continuous operation or for an Acknowledge mode of operation where the Display key is pressed to acknowledge and cancel the relay alarm output.

#### Normally Energised or De-energised Relay

Relays are programmable to alarm in either mode.

### Non-Linearity Correction

A 25 point non-linear correction table can be programmed to handle any shaped tank. Up to 25 points on both the x and y axis can be programmed and the Model 220 will perform linear interpolation between points.

The curve enables the contents of vessels, such as cylindrical tanks, bullet shaped tanks or hoppers to be displayed directly in engineering units as a volume or mass.

A conversion program which runs under Windows 95 is available to calculate theoretical values for the conversion program based on tank dimensions.

### Mains Powered Relay Module

A DIN rail mounted module is available as an option which provides:

- ▶ 24Vdc at 50 mA max for powering the 4-20 mA current loop.
- ▶ Four relays rated at 240V ac, 3A max.

The module is designed such that it can be mounted remotely from the Model 220, but easily wired to the instrument.

### Intrinsic Safety

The Model 220 is certified as intrinsically safe to European ATEX standards, and CSA<sub>US/C</sub> standards covering both the USA and Canada.



# LEVEL MONITOR

## Specifications Model 220

### General

<b>Display</b>	LCD
<b>Level</b>	20 segment bar graph
<b>Level Span</b>	0...100% proportional to input signal For non-inverting tanks 0% is 4mA and 100% is 20mA For inverting tanks 0% equals 20mA and 100% is 4mA
<b>Contents</b>	7 digits with 12mm (0.48") high digits on the LCD. Contents are displayed with 4 1/2 digit resolution and trailing zeros
<b>Contents Span</b>	The contents span is programmable in the range of 0.001...9,999,999 and can be any unit of measure
<b>Content Zero</b>	The contents zero is programmable in the range of 0.000...9,999,999. The contents zero is the contents in the tank at 0% level
<b>Decimal Points</b>	Decimal point position for contents is programmable in range of 0...3 decimal point places

### 4-20mA Input

<b>Resolution and Linearity</b>	0.05% of span
<b>Accuracy</b>	0.05% of span @ 25°C 0.1%(typ) of span, full temperature range
<b>Update Time</b>	0.5 second
<b>Connection</b>	Two wire
<b>Voltage Drop</b>	2.5 volts maximum

### Alarm / Pulse Outputs

<b>Type</b>	Four open collector outputs suitable for driving DC solenoids or external relays. The outputs provide high, high-high, low and low-low flow alarms
<b>Switching Power</b>	200mA. 30Vdc maximum
<b>Saturation Voltage</b>	0.8 Vdc typical across the output in the "on" state
<b>Isolation</b>	Output are separately opto-isolated

### Relay and Power Module

The Model RPS24 Relay & Power Module is a DIN rail mounted module that provides a 24 Vdc loop power supply which can be used to power both the transmitter and Model 220.

In addition, the RPS24 has four electromechanical relays which can be connected directly to the open collector outputs in the Model 220 to provide switchable AC outputs.

### Physical

<b>Temperature</b>	Operating temperature: -20°C to 60°C
<b>Dimensions</b>	98mm (3.9") (h) x 152mm (6.0") (w) x 43mm (1.7") (d) (cable glands not included)
<b>Protection</b>	Sealed to Nema 4X or IP67 standards
<b>Mounting Options</b>	
Wall	Universal mounting bracket supplied as standard
Pipe	A galvanised metal bracket is available which enables the Model 220 to be attached to a 2" vertical or horizontal pipe
Panel	Supplied with mounting brackets. Terminals accessible from rear. (Note that the panel mount version is not watertight)

### Intrinsically Safe Parameters

<b>Type of Approvals</b>	
ATEX	Type II 2G EEx ia IIB T4
CSA <sub>US/C</sub>	Type Class 1, Groups C & D
<b>4-20mA Input</b>	U <sub>i</sub> = 28V max I <sub>i</sub> = 93mA max P <sub>i</sub> = 653mW max
<b>Relay Outputs</b>	U <sub>i</sub> = 28V max I <sub>i</sub> = 93mA max P <sub>i</sub> = 653mW max

### Terminal Descriptions

Number		Number	
1	Low-low Alarm (-)	6	Low Alarm (+)
2	Low-low Alarm (+)	7	High Alarm (-)
3	4-20mA (-) Input	8	High Alarm (+)
4	4-20mA (+) Input	9	High-high Alarm (-)
5	Low Alarm (-)	10	High-high Alarm (+)

Important: Specifications are subject to change without notice

### Product Codes

220	.	Level Monitor
Intrinsic Safety	i	Intrinsically safe Not intrinsically safe
Enclosure and Mounting	0	Wall Mounting (no glad holes)
	1	Pipe Mount
	2	Wall Mounting (Standard glands)
	6	Pipe Mount
Hazardous Approvals	C	CSA US & Canadian Approval
	M	ATEX Approval
	S	SAA Australian Approval
		No Approvals

Typical Part Number: 220i.0C

# LOOP POWERED PROCESS INDICATOR

## Model 250A



### Overview

The Model 250A Programmable Process Indicator accepts a 4-20 mA signal from a wide range of transducers such as pressure or temperature transmitters, weigh scales, pH sensors, flowmeters or level transmitters. The Indicator will display the signal level on the bar graph and the scaled process variable on the large numeric display.

Solid state relay outputs provide up to four level alarms and a 25 point non-linearity correction table allows the instrument to be programmed for non-linear signals.

The Process Indicator is powered entirely from the 4-20 mA current loop and, therefore, requires no external power or batteries.

The instrument is fully programmable with setup parameters such as span, offset, alarm levels, etc, stored in a non-volatile memory which will retain all data for more than 10 years without power.

The Model 250A is housed in an attractive IP67 (Nema 4X) polycarbonate enclosure which is completely watertight.

A wall mounting bracket is supplied as standard, while a 2" pipe mounting bracket is available as an option.

Alternatively, the Model 250A can be supplied as a panel mount instrument.

### Display

#### Signal bar graph

Displays measured signal as a percentage (0-100%).

#### Process Variable

7 digit numeric display of the process variable. This is calculated from programming the span, zero offset and non-linearity correction, if applicable.

The process variable is displayed with 4 1/2 digit resolution so that larger values are displayed with trailing zeros (for example, 1437765 would be displayed as 1437700 and 5467289 would be displayed as 5467000).

#### Filter

A programmable filter will smooth out fluctuations in readings.

### Relays

#### Type

Four solid state opto-isolated dc relays arranged as high-high, high, low and low-low.

An optional DIN rail mounted relay module is available which incorporates mains operated relays.

#### Acknowledgement

Alarms can be programmed for continuous operation or for an Acknowledge mode of operation where the Display key is pressed to acknowledge and cancel the relay alarm output.

#### Normally energised or de-energised relay

Relays are programmable to alarm in either mode.

### Non-Linearity Correction

A 25 point non-linear correction table can be programmed to handle any non-linear relationship between the signal input and the process variable. Up to 25 points on both the x and y axis can be programmed and the Model 250A will perform linear interpolation between points.

### Mains Powered Relay Module

A DIN rail mounted module is available as an option which provides:

- ▶ 24Vdc at 50 mA max for powering the 4-20 mA current loop.
- ▶ Four relays rated at 240V ac, 3A max.

The module is designed such that it can be mounted remotely from the Model 250A, but easily wired to the instrument.

### Intrinsic Safety

The Model 250A is certified as intrinsically safe to European ATEX standards, and CSA<sub>US/IC</sub> standards covering both the USA and Canada.



# LOOP POWERED PROCESS INDICATOR

## Specifications Model 250A

### General

<b>Display</b>	LCD
<b>Signal</b>	20 segment bar graph
<b>Signal Span</b>	0...100% proportional to input signal For non-inverting signals 0% is 4mA and 100% is 20mA For inverting signals 0% equals 20mA and 100% is 4mA
<b>Process Variable</b>	7 digits with 12mm (0.48") high digits on the LCD. The process variable is displayed with 4 1/2 digit resolution and trailing zeros
<b>Process Span</b>	The process span is programmable in the range of 0.001...9,999,999 and can be any unit of measure
<b>Process Zero</b>	The process zero is programmable in the range of 0.000...9,999,999.
<b>Decimal Points</b>	Decimal point position for contents is programmable in range of 0...3 decimal point places

### 4-20mA Input

<b>Resolution and Linearity</b>	0.05% of span
<b>Accuracy</b>	0.05% of span @ 25°C 0.1%(typ) of span, full temperature range
<b>Update Time</b>	0.5 second
<b>Connection</b>	Two wire
<b>Voltage Drop</b>	2.5 volts maximum

### Alarm / Pulse Outputs

<b>Type</b>	Four open collector outputs suitable for driving DC solenoids or external relays. The outputs provide high, high-high, low and low-low flow alarms
<b>Switching Power</b>	200mA. 30Vdc maximum
<b>Saturation Voltage</b>	0.8 Vdc typical across the output in the "on" state
<b>Isolation</b>	Output are separately opto-isolated

### Relay and Power Module

The Model RPS24 Relay & Power Module is a DIN rail mounted module that provides a 24 Vdc loop power supply which can be used to power both the transmitter and Model 250A.

In addition, the RPS24 has four electromechanical relays which can be connected directly to the open collector outputs in the Model 250A to provide switchable AC outputs.

### Physical

<b>Temperature</b>	Operating temperature: -20°C to 60°C
<b>Dimensions</b>	98mm (3.9") (h) x 152mm (6.0") (w) x 43mm (1.7") deep (cable glands not included)
<b>Protection</b>	Sealed to Nema 4X or IP67 standards
<b>Mounting Options</b>	
<b>Wall</b>	Universal mounting bracket supplied as standard
<b>Pipe</b>	A galvanised metal bracket is available which enables the Model 250A to be attached to a 2" vertical or horizontal pipe
<b>Panel</b>	Supplied with mounting brackets. Terminals accessible from rear. (Note that the panel mount version is not watertight)

### Intrinsically Safe Parameters

<b>Type of Approvals</b>	
<b>ATEX</b>	II 2G EEx ia IIB T4
<b>CSA<sub>US/C</sub></b>	Class 1, Groups C & D
<b>4-20mA Input</b>	U <sub>i</sub> = 28V max I <sub>i</sub> = 93mA max P <sub>i</sub> = 653mW max
<b>Relay Outputs</b>	U <sub>i</sub> = 28V max I <sub>i</sub> = 93mA max P <sub>i</sub> = 653mW max

### Terminal Descriptions

Number		Number	
1	Low-low Alarm (-)	6	Low Alarm (+)
2	Low-low Alarm (+)	7	High Alarm (-)
3	4-20mA (-) Input	8	High Alarm (+)
4	4-20mA (+) Input	9	High-high Alarm (-)
5	Low Alarm (-)	10	High-high Alarm (+)

Important: Specifications are subject to change without notice

### Product Codes

250A	.	Loop Powered Process Indicator
Intrinsic Safety	i	Intrinsically safe
		Not intrinsically safe
Enclosure and Mounting	0	Wall Mounting (no glad holes)
	1	Panel Mount
	2	Wall Mounting (Standard glands)
	6	Pipe Mount
Hazardous Approvals	C	CSA US & Canadian Approval
	M	ATEX Approval
	S	SAA Australian Approval
		No Approvals

Typical Part Number: 250A.0C

## Model 405



### Overview

The 405 Flow Computer can handle a wide range of flow applications, where high accuracy and flexibility are required. It will interface to most flowmeters and versions are available for pulse and analog inputs.

Either the **Flow Rate** or a **Resettable Total** can be continuously displayed in engineering units on the large six digit LCD display. A non-resettable **Accumulated Total** is also displayed whenever the **DISPLAY** key is pressed.

A scaled pulse output, suitable for driving remote totalisers, is a standard feature and the instrument also provides an 8-24 Volts dc power supply for driving transducers.

### RS232 and RS422/1485 Communications Interface

Optional features include: an isolated 4-20 mA output; a communications interface; and high / low flow rate alarms which are output on two Form C relays.

The communications option includes both RS232 and RS422 / 485 interfaces for communicating with a computer.

Software drivers are also included for a number of printers and can print a ticket with time and date, a sequential ticket number, and the resettable and accumulated totals.

### Set-up Data is Stored in Non-volatile Memory

The 405 is initially set-up by following a calibration sequence that enables scaling factors, digital filtering and display formatting to be set and stored in a non-volatile memory which does not require battery backup.

The instrument will operate from 12 to 28V dc or from the 110/220V ac mains.

Each flow computer is supplied with a sheet of self-adhesive engineering unit labels. A recess, adjacent to the display, is provided in which the correct label can be placed.

### Digital Filtering Enhances Rate Accuracy

Frequency fluctuations caused by pulsating flow through a flowmeter, often makes the Rate impossible to read with any precision.

The 405 has a digital filter which will average out these fluctuations and enable the Rate to be read to a four digit accuracy.

The degree of filtering is fully programmable which means that highly accurate and stable readings can be obtained without excessive lag.

### Different Mounting Options Available

The 405 is designed for panel mounting with the fascia watertight to IP65 (Nema 4X) and resistant to most chemicals.

A field enclosure and an explosion-proof enclosure are optionally available.

## Model Available

### Model 405A

An analog version with a fully isolated input. Inputs include 4-20 mA, 0-20 mA, 1-5V and 0-10V signals from flowmeters and pressure transducers. In addition to linear and square law input relationships, open channel applications can be handled via a programmable power on the input relationship.

### Model 405B

A frequency input version that will accept pulse inputs and open collector inputs from opto-sensors or Hall effect devices.

### Model 405D

Frequency input version with an input conditioning card capable of accepting mV signals from coils, two wire proximity sensors, reed switch inputs and most other pulse type signals.

### Model 405LA

4-20 mA temperature input version with temperature correction for general chemicals, LPG and petroleums to API tables. (see separate data sheet on 405L and 414L)

### Model 405LR

RTD temperature input version with temperature correction for general chemicals, LPG and petroleums to API tables. (see separate data sheet on 405L and 414L)

### Model 405Q

Frequency or pulse input with non-linearity correction and quadrature signal for measurement of bi-directional flows. The 405Q is highly suited to custody transfer applications where high accuracy and signal integrity is required.

### Model 405S

For applications requiring the addition or subtraction of two flows this instrument will accept two frequency inputs and display Rate and Total for each channel.

## Operation

The display of the 405 will normally show the Rate or Resettable Total (Net Total in the case of the 405LA, 405LR and 405S), as selected by the **RATE** or **TOTAL** keys on the keypad. An LED in the fascia will indicate which function is currently displayed.

The **DISPLAY** key can be used to display the Accumulated Total. On the first press of the **DISPLAY** key, the display shows **ACCTOT** for one second followed by the actual total.

The Accumulated Total continuously totalises the flow and is not resettable via the front panel.

On reaching the maximum displayed total, all totals will roll over to zero and continue totalising. If, at any time, power is lost or the instrument is switched off, the totals will be stored in the non-volatile memory. When power is switched back on to the instrument, the stored totals will be recalled from memory and the totals will be incremented from the last values.

In the case of the Models 405LA and 405LR, if temperature compensation is selected, a second press of the **DISPLAY** key will show the product temperature or density if a density meter input is selected. A third press of the **DISPLAY** will show the actual Gross Total.

With the 405S, the first press of the **DISPLAY** key will show RATE 1, and the second press TOTAL 1, for input 1. The third press will show RATE 2, and the fourth press TOTAL 2, for input 2.



# FLOW COMPUTER

## Specifications Model 405

### General

<b>Display</b>	6 digit 0.7" (17.8mm) high LCD
<b>Display Update Rate</b>	0.25s (0.5s on 405A)
<b>Data Retention</b>	Set-up parameters and totals stored in non-volatile memory with 10 years retention
<b>Decimal Points</b>	The number of decimal points with which the rate and totals are displayed can be programmed
<b>Total Conversion</b>	It is possible to program a constant so that the rate can be displayed in one unit (eg. gal/m) and the total displayed with a different unit (eg. barrels)
<b>Time Base</b>	The rate can be displayed in units per second, minutes, hours or days
<b>Transducer Supply</b>	8-24V dc field adjustable, 50 mA maximum
<b>Power Requirements</b>	
DC Supply	11.5-28.5V dc, 130 mA typical current (no options)
AC Supply	Set internally to 85-100V, 95-135V or 190-260V
<b>Operating Temp.</b>	0 to 55°C
<b>Rear Connection</b>	Terminal block
<b>Front Panel</b>	
Material	Polycarbonate
Protection	IP65 (Nema 4X)
<b>Case</b>	Aluminium

### Inputs

<b>Analog Input (Model 405A)</b>	
Type	Isolated 4-20 mA, 0-20 mA, 1-5V and 0-10V
Input Impedance	
Current	250 ohms
Voltage	10K ohms
Accuracy	0.075%
Span	0.1000 to 50,000
Zero	0.00000 to 50,000
Cut-off Point	A low flow rate cut-off can be programmed below which flow is not registered. The cut-off is programmed as a percentage of span
Relationship	Linear, square root or programmable
Open Channel	For open channel flowmeters the power of the input relationship is programmable between 0 and 9.99. With open channel selected, the polarity of the signal can also be programmed such that, 20 mA represents maximum or minimum flow
<b>Frequency (Pulse) Input (Models 405B, 405D, 405Q and 405S)</b>	
Minimum	0Hz on Totals, 0.25Hz on Rate.
Maximum	10kHz for single input, 2.5 for quadrature
Input Circuits	Will accept most sine logic and proximity switch inputs
Scaling Range	0.1000 to 50,000
<b>4-20 mA Inputs</b>	(Flow and Temperature in the Model 405LA - see separate data sheet.)
<b>RTD Input</b>	(Model 405LR - see separate data sheet.)

### Outputs

<b>Pulse Output (Not available for Model 405s)</b>	
Type	Open collector output with a pulse produced on each increment of the accumulated total
Maximum Rate	49 pulses per second
Pulse Width	10ms
Maximum Current	Current sinking transistor output 100 mA, 30V dc maximum
<b>4-20 mA Output</b>	
Type	Fully isolated output corresponding to the displayed flow rate, suitable for driving a recorder or controller. Outputs available are 4-20 mA, 0-20 mA 0-10 V or 2-1 OV, with the minimum and maximum levels programmable
Resolution	10 bits
Accuracy	< 0.05%
Maximum Load	500 ohms from internal power, 950 ohms if externally powered
<b>Communications Output</b>	
Type	RS232, RS422 or RS485 interface is available for driving printers and communicating with computers
Baud Rate	300 to 9600
Parity	None, odd and even
Data Bits	7 or 8
Protocols	A number of protocols are included to interface to printers and computers
Time / Date	A real time clock provides time / date printing on tickets
ID Code	For multi-point communications, a unique address can be programmed
<b>High / Low Flow</b>	
Type	Two Form C relays provide a high and low flow rate alarm. Alarm points are programmable during set-up
Maximum Current	5A
Maximum Voltage	250V ac, 30V dc
Maximum Power	1250VA

### Approvals

<b>Electrical</b>	ETL (US) approved to UL508 and CSA
<b>Interference</b>	CE Compliance

### Optional Enclosures

<b>Field Enclosures</b>	IP67 (Nema 4X)
<b>Explosionproof Enclosures</b>	CENELEC, FM, CSA and SAA approved enclosures available for hazardous areas.

Important: Specifications are subject to change without notice.

## Dimension Drawings

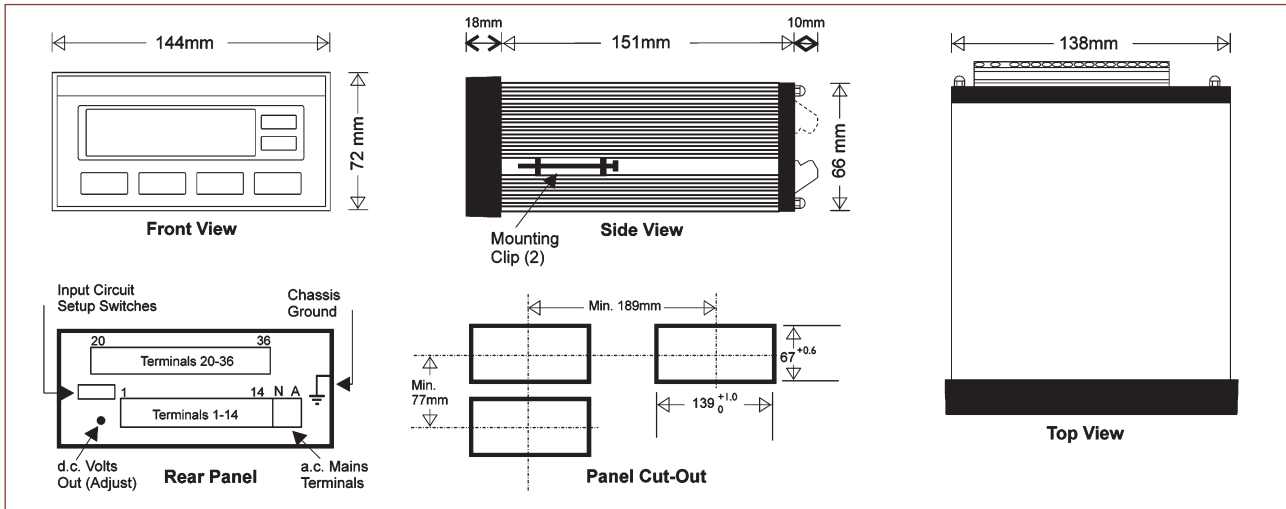

## Terminal Descriptions Model 405

Terminals Common to all Models	
No.	Description
1	Calibration
2	Switch Common
11	DC Power Out
12	DC Ground
13	DC Power In

RS232/422 Option (All Models)	
No.	Description
20	RS232 Signal Ground
21	RS232 Data In
22	RS232 Data Out
23	RS422 (-) Data Out
24	RS422 (+) Data Out
25	RS422 (-) Data In
26	RS422 (+) Data In
27	RS232 CTS

Isolated 4-20 mA Output Option	
No.	Description
20	Not Used
21	0 Volts
22	0-10 Volts Out
23	-12 volts
24	I (-)
25	I (+)
26	+15 Volts
27	Not Used

High & Low Relay Alarm Option	
No.	Description
31	High - Normally Open
32	High - Normally Closed
33	High - Common
34	Low - Normally Open
35	Low - Normally Closed
36	Low - Common

Note: Terminals 28, 29, & 30 on the option card are not used.

## Terminals Specific to Each Model

No.	405A	405B	405D	405LA	405LR	405Q 405S	No.
3	Rate Switch	Not Used	Rate Switch	Flow Input Ch. 2	Flow Input Ch. 2	Flow Input Ch. 2	3
4	Total Switch	Not Used	Total Switch	Not Used	PT100 (+)	Not Used	4
5	Reset Switch	Not Used	Reset Switch	Temp. (4-20mA)	PT100 Signal (+)	Not Used	5
6	Program Switch	Not Used	Program Switch	Not Used	PT100 Signal (-)	Not Used	6
7	Not Used	Not Used	Not Used	Flow Alarm	Flow Alarm	Flow Alarm	7
8	Flow Common	Flow Common	Flow Common	Flow Common	Flow Common	Flow Common	8
9	Flow Signal (mA)	Flow Signal	Flow Signal	Flow Input Ch. 1	Flow Input Ch. 1	Flow Input Ch. 1	9
10	Pulse Out	Not Used	Pulse Out	Pulse Out	Pulse Out	Pulse Out	10
14	Flow Signal (Volts)	Not Used	Not Used	Flow Input (4-20mA)	PT100(-)	Not Used	14

## Ordering Information

When specifying please indicate model(s) required using the following method.

**405 D . 1 0 E 0**

<p><b>Basic Model</b></p> <p><b>Type of Input</b></p> <p>Analog Input - A</p> <p>Pulse Input - B</p> <p>Pulse or frequency input with signal conditioner - D</p> <p>Liquid temperature compensation (4-20mA) - LA</p> <p>Liquid temperature compensation (RTD) - LR</p> <p>Quadrature pulse input - Q</p> <p>Addition/Subtraction of two flows - S</p>		<p><b>Special Options</b></p> <p>0 - No Option</p> <p>B - Backlighting</p> <p>C - Conformal Coating</p> <p><b>Power Supply</b></p> <p>E - 220-240V ac</p> <p>A - 110-120V ac</p> <p>D - 12-28V dc</p> <p>J - 100V ac</p> <p><b>Output Options</b></p> <p>0 - No options</p> <p>1 - Isolated 4-20mA output</p> <p>2 - RS232/422/485</p> <p>3 - High/Low alarms</p> <p>4 - 4-20mA and alarms</p> <p>5 - RS232/422/485 and alarms</p> <p><b>Mounting Options</b></p> <p>1 - Panel mount</p> <p>N - Field mount enclosure</p> <p>3 - Explosionproof enclosure (CENELEC)</p>
--	--	---



# GAS & STEAM FLOW COMPUTER

## Model 415



### Overview

The 415 Steam and Gas Flow Computer incorporates the following compensation equations for gas and vapours:

- **Ideal Gas Law** using temperature and pressure correction, but where compressibility correction is not required.
- **General Gases** where compressibility is calculated using the Redlich-Kwong<sup>1</sup> state equation. This equation is suitable for gases which have known properties, and information on common industrial gases is provided in the operating manual.
- **Natural Gas** using the NX-19<sup>2</sup> equation to calculate super compressibility.
- **Steam Equations** for both saturated and superheated steam. Mass and energy flow rates are calculated using standard equations to determine the specific weight and enthalpy of steam.

### RTD or 4-20 mA temperature outputs

The backlit alphanumeric display simplifies programming and provides a clear indication of all parameters, as well as engineering units. The 415 is fully programmable and all operating parameters are entered via the front panel keypad.

The instrument is available with direct RTD input (415R) or with 4-20 mA temperature input (415A). Both accept a 4-20 mA pressure input.

### Wide range of flowmeter inputs

Inputs from a wide range of flowmeters are accepted, including vortex, turbine, orifice plate, averaging pitot tubes, wedges and target flowmeters. Also, where two differential pressure transmitters are used across an orifice or similar device, to increase the measured flow range, both DP transmitter inputs are accepted and scaled separately with automatic crossover.

A scaled output, suitable for driving remote totalisers, is a standard feature. Options include an isolated 4-20 mA retransmission, high and low flow alarms and an RS232/422 output which will operate on either the mass, corrected volume or energy outputs, depending on which value is programmed as the default display.

### RS232 / 422 output enables data logger operation

The RS232 / 422 option will output all parameters displayed and has the unique ability to print flow rates and totals at programmable time intervals. This enables the 415 to function as a data logger when used in conjunction with a printer or other storage device.

Protocols are provided for standard roll and column printers as well as for computer interfaces and a real time clock provides time and date. The totals can be programmed to reset via the front panel, after each print or at 24:00 hours.

### Flowmeter Inputs

The 415 accepts most flowmeter inputs including:

- **Frequency** producing flowmeters such as vortex, turbine or positive displacement.
- **Volumetric** flowmeters with 4-20 mA outputs such as vortex or turbines with a frequency to current converter on the output.
- **Differential Pressure** devices such as orifice plates, averaging pitot tubes, wedges, cones, elbows or target flowmeters, where a square law relationship applies.
- **Linear Differential Pressure** devices where the 4-20 mA output is directly proportional to the flow rate.
- **Dual Range (Stacked) Differential Pressure Transmitters** where two separately spanned transmitters are used across a common flow device such as an orifice (both square and linear inputs).
- **Non-Linear Differential Pressure** devices such as laminar flow tubes or VA meters. A 20 point correction curve can be programmed to compensate for any non-linearities in the flowmeter.

### Parameters Displayed

Information is displayed in a number of windows which can be selected using the **DISPLAY** key.

#### General

**Flow rate** of the mass, corrected volume or energy is displayed in units per day, hour, minute or second.

**Total** of the mass, corrected volume or energy. A reset key on the front panel enables totals to be reset, or the key can be disabled during setup. Totals are displayed with 8 digits.

#### Gas Flow

Corrected volume at base conditions

(m<sup>3</sup> or ft<sup>3</sup>)

Mass (kg or lbs)

Temperature (°C or °F)

Pressure (kPa or psi) in absolute or gauge

Compressibility Z, for general gases

Super compressibility  $F_{pv}$  for natural gas

#### Steam Flow

Mass (kg or lbs)

Energy (MJ or Btu x 1000)

Temperature (°C or °F)

Pressure (kPa or psi) in absolute or gauge

Specific weight in dm<sup>3</sup>/kg

Specific enthalpy in kJ/kg

# GAS & STEAM FLOW COMPUTER

## Specifications Model 415

### General

<b>Display</b>	2 line x 20 character (5.5mm high) alphanumeric backlit LCD
<b>Keypad</b>	Sealed membrane keypad with four keys
<b>Transducer Supply</b>	8-24V dc field adjustable, 65 mA max
<b>Power Requirements</b>	
DC Supply	14 to 28V DC, 300 mA typical (no options)
AC Supply	AC mains set internally to 95-135V AC or 190-260V AC
<b>Operating Temperature</b>	0 to 55°C
<b>Facia Sealing</b>	IP65 (Nema 4X) watertight

### Approvals

<b>Electrical</b>	ETL (US) approved to UL508 and CSA
<b>Interference</b>	CE Compliance
<b>Enclosure</b>	CENELEC, FM, CSA and SAA approved enclosures available for hazardous areas

### Frequency Input

<b>Range</b>	
Minimum	0.25Hz on Rate, 0Hz on Total
Maximum	10KHz
<b>Input Circuits</b>	Accepts most sine, logic and proximity switch inputs
<b>K-factor Range</b>	0.1000 to 999,999
<b>Non-Linear Correction</b>	Up to 10 correction points

### 4-20mA Inputs

<b>Input Types</b>	Flow (2 ranges), pressure and temperature
<b>Input Impedance</b>	250 ohms
<b>Measurement Range</b>	
Pressure	0 kPa abs (0 psia) to 100,000 kPa abs (10,000 psia)
Temperature	-273°C (459.4°F) to 1200°C (2192°F)
<b>Span (flow)</b>	999,999
<b>Accuracy</b>	0.05%
<b>Circuit</b>	250 ohm resistors connected to a common signal ground (current sinking)
<b>Non-Linear Correction</b>	A 20 point curve can be applied to the flow input

### RTD Input (Model 415R)

<b>Type</b>	Platinum PT100
<b>Range</b>	-100°C (-148°F) to 200°C (392°F) (Note a wider temperature range can be handled via a 4-20 mA input)
<b>Accuracy</b>	0.1°C
<b>Linearity</b>	The non-linearity of the RTD is internally compensated for

### Pressure Input

<b>Type</b>	Absolute or gauge
<b>Span</b>	Absolute or gauge pressure is programmable at 4 mA and 20 mA
<b>Atmospheric</b>	If a gauge pressure sensor is used, the atmospheric pressure is programmable

### Pulse Output

<b>Pulse Width</b>	10ms (negative going pulse)
<b>Duty Cycle</b>	49 pulses / sec max
<b>Output</b>	Open collector transistor will sink 100 mA max. (Note: Suitable for driving remote counters or PLC's)

### RS232/422 Option

<b>Type</b>	Both RS232 and RS422 are provided. (Note: When using the RS422, multi-point communication (RS485) can be implemented with up to 32 instruments connected to a common bus.)
<b>Function</b>	Printer and computer protocols are fully programmable.
<b>Printer</b>	A print is initiated on each reset or at a programmable time interval. (Note: Protocols are provided for roll & column printers.)
<b>Computer</b>	An ASCII based protocol enables all displayed parameters to be read and the totals to be reset.
<b>Baud rate</b>	300 to 9600.
<b>Data Bits</b>	7 or 8.
<b>Parity</b>	None, Odd or Even.
<b>Data Logging</b>	Output generated at intervals of once a minute to once every 24 hours. The totals can be programmed to reset on each print or at 24:00 hours.
<b>Time</b>	A real time clock is provided to give time and date on each output.

### 4-20 mA Output Option

<b>Function</b>	Outputs flow rate in mass, corrected volume or energy. The 4 and 20 mA points can be programmed to provide a fully scaled output
<b>Resolution</b>	10 bits
<b>Accuracy</b>	Better than 0.1
<b>Maximum Load</b>	500 ohms internally powered 950 ohms from external 24V dc
<b>Isolation</b>	Output is isolated

### Relay Output Option

<b>Function</b>	High and low flow rate alarms based on the flow rate in mass, corrected volume or energy
<b>Maximum Ratings</b>	
Power	250VA
Voltage	250V AC, 30V DC
Current	5 Amps

### Ideal Gas

<b>Display</b>	
Corrected Volume	m <sup>3</sup> or ft <sup>3</sup>
Mass	kg or lbs
<b>Temperature Range</b>	-273°C (-450°F) to 800°C (1472°F)
<b>Pressure Range</b>	0 kPa abs (0 psia) to 100,000 kPa abs (10,000 psia)

### General Gas

<b>Gases</b>	Handles most gases for which the critical temperature, pressure and specific gravity are known
<b>Compressibility</b>	Calculated using the Redlich-Kwong <sup>1</sup> equation
<b>Temperature Range</b>	-273°C (450°F) to 800°C (1472°F) (RTD has a more limited range)
<b>Pressure Range</b>	0 kPa abs (0 psia) to 100,000 kPa abs (10,000 psia)

