

GAS & STEAM FLOW COMPUTER

Model 415



Overview

The 415 Steam and Gas Flow Computer incorporates the following compensation equations for gas and vapours:

- **Ideal Gas Law** using temperature and pressure correction, but where compressibility correction is not required.
- **General Gases** where compressibility is calculated using the Redlich-Kwong¹ state equation. This equation is suitable for gases which have known properties, and information on common industrial gases is provided in the operating manual.
- **Natural Gas** using the NX-19² equation to calculate super compressibility.
- **Steam Equations** for both saturated and superheated steam. Mass and energy flow rates are calculated using standard equations to determine the specific weight and enthalpy of steam.

RTD or 4-20 mA temperature outputs

The backlit alphanumeric display simplifies programming and provides a clear indication of all parameters, as well as engineering units. The 415 is fully programmable and all operating parameters are entered via the front panel keypad.

The instrument is available with direct RTD input (415R) or with 4-20 mA temperature input (415A). Both accept a 4-20 mA pressure input.

Wide range of flowmeter inputs

Inputs from a wide range of flowmeters are accepted, including vortex, turbine, orifice plate, averaging pitot tubes, wedges and target flowmeters. Also, where two differential pressure transmitters are used across an orifice or similar device, to increase the measured flow range, both DP transmitter inputs are accepted and scaled separately with automatic crossover.

A scaled output, suitable for driving remote totalisers, is a standard feature. Options include an isolated 4-20 mA retransmission, high and low flow alarms and an RS232/422 output which will operate on either the mass, corrected volume or energy outputs, depending on which value is programmed as the default display.

RS232 / 422 output enables data logger operation

The RS232 / 422 option will output all parameters displayed and has the unique ability to print flow rates and totals at programmable time intervals. This enables the 415 to function as a data logger when used in conjunction with a printer or other storage device.

Protocols are provided for standard roll and column printers as well as for computer interfaces and a real time clock provides time and date. The totals can be programmed to reset via the front panel, after each print or at 24:00 hours.

Flowmeter Inputs

The 415 accepts most flowmeter inputs including:

- **Frequency** producing flowmeters such as vortex, turbine or positive displacement.
- **Volumetric** flowmeters with 4-20 mA outputs such as vortex or turbines with a frequency to current converter on the output.
- **Differential Pressure** devices such as orifice plates, averaging pitot tubes, wedges, cones, elbows or target flowmeters, where a square law relationship applies.
- **Linear Differential Pressure** devices where the 4-20 mA output is directly proportional to the flow rate.
- **Dual Range (Stacked) Differential Pressure Transmitters** where two separately spanned transmitters are used across a common flow device such as an orifice (both square and linear inputs).
- **Non-Linear Differential Pressure** devices such as laminar flow tubes or VA meters. A 20 point correction curve can be programmed to compensate for any non-linearities in the flowmeter.

Parameters Displayed

Information is displayed in a number of windows which can be selected using the **DISPLAY** key.

General

Flow rate of the mass, corrected volume or energy is displayed in units per day, hour, minute or second.

Total of the mass, corrected volume or energy. A reset key on the front panel enables totals to be reset, or the key can be disabled during setup. Totals are displayed with 8 digits.

Gas Flow

Corrected volume at base conditions

(m³ or ft³)

Mass (kg or lbs)

Temperature (°C or °F)

Pressure (kPa or psi) in absolute or gauge

Compressibility Z, for general gases

Super compressibility F_{pv} for natural gas

Steam Flow

Mass (kg or lbs)

Energy (MJ or Btu x 1000)

Temperature (°C or °F)

Pressure (kPa or psi) in absolute or gauge

Specific weight in dm³/kg

Specific enthalpy in kJ/kg

GAS & STEAM FLOW COMPUTER

Specifications Model 415

General

Display	2 line x 20 character (5.5mm high) alphanumeric backlit LCD
Keypad	Sealed membrane keypad with four keys
Transducer Supply	8-24V dc field adjustable, 65 mA max
Power Requirements	
DC Supply	14 to 28V DC, 300 mA typical (no options)
AC Supply	AC mains set internally to 95-135V AC or 190-260V AC
Operating Temperature	0 to 55°C
Facia Sealing	IP65 (Nema 4X) watertight

Approvals

Electrical	ETL (US) approved to UL508 and CSA
Interference	CE Compliance
Enclosure	CENELEC, FM, CSA and SAA approved enclosures available for hazardous areas

Frequency Input

Range	
Minimum	0.25Hz on Rate, 0Hz on Total
Maximum	10KHz
Input Circuits	Accepts most sine, logic and proximity switch inputs
K-factor Range	0.1000 to 999,999
Non-Linear Correction	Up to 10 correction points

4-20mA Inputs

Input Types	Flow (2 ranges), pressure and temperature
Input Impedance	250 ohms
Measurement Range	
Pressure	0 kPa abs (0 psia) to 100,000 kPa abs (10,000 psia)
Temperature	-273°C (459.4°F) to 1200°C (2192°F)
Span (flow)	999,999
Accuracy	0.05%
Circuit	250 ohm resistors connected to a common signal ground (current sinking)
Non-Linear Correction	A 20 point curve can be applied to the flow input

RTD Input (Model 415R)

Type	Platinum PT100
Range	-100°C (-148°F) to 200°C (392°F) (Note a wider temperature range can be handled via a 4-20 mA input)
Accuracy	0.1°C
Linearity	The non-linearity of the RTD is internally compensated for

Pressure Input

Type	Absolute or gauge
Span	Absolute or gauge pressure is programmable at 4 mA and 20 mA
Atmospheric	If a gauge pressure sensor is used, the atmospheric pressure is programmable

Pulse Output

Pulse Width	10ms (negative going pulse)
Duty Cycle	49 pulses / sec max
Output	Open collector transistor will sink 100 mA max. (Note: Suitable for driving remote counters or PLC's)

RS232/422 Option

Type	Both RS232 and RS422 are provided. (Note: When using the RS422, multi-point communication (RS485) can be implemented with up to 32 instruments connected to a common bus.)
Function	Printer and computer protocols are fully programmable.
Printer	A print is initiated on each reset or at a programmable time interval. (Note: Protocols are provided for roll & column printers.)
Computer	An ASCII based protocol enables all displayed parameters to be read and the totals to be reset.
Baud rate	300 to 9600.
Data Bits	7 or 8.
Parity	None, Odd or Even.
Data Logging	Output generated at intervals of once a minute to once every 24 hours. The totals can be programmed to reset on each print or at 24:00 hours.
Time	A real time clock is provided to give time and date on each output.

4-20 mA Output Option

Function	Outputs flow rate in mass, corrected volume or energy. The 4 and 20 mA points can be programmed to provide a fully scaled output
Resolution	10 bits
Accuracy	Better than 0.1
Maximum Load	500 ohms internally powered 950 ohms from external 24V dc
Isolation	Output is isolated

Relay Output Option

Function	High and low flow rate alarms based on the flow rate in mass, corrected volume or energy
Maximum Ratings	
Power	250VA
Voltage	250V AC, 30V DC
Current	5 Amps

Ideal Gas

Display	
Corrected Volume	m ³ or ft ³
Mass	kg or lbs
Temperature Range	-273°C (-450°F) to 800°C (1472°F)
Pressure Range	0 kPa abs (0 psia) to 100,000 kPa abs (10,000 psia)

General Gas

Gases	Handles most gases for which the critical temperature, pressure and specific gravity are known
Compressibility	Calculated using the Redlich-Kwong ¹ equation
Temperature Range	-273°C (450°F) to 800°C (1472°F) (RTD has a more limited range)
Pressure Range	0 kPa abs (0 psia) to 100,000 kPa abs (10,000 psia)



GAS & STEAM FLOW COMPUTER

Natural Gas

Calculations	Uses NX-19 ² equation to calculate super compressibility F_{pv}°
Temperature Range	-40°C (-40°F) to 115°C (240°F)
Pressure Range	101.325 kPa abs (14.69 psia) to 34,380 kPa abs (4985 psia)
Specific Gravity Range	0.554 to 1.000
Carbon Dioxide	0 to 15% mole
Nitrogen	0 to 15% mole

¹ Redlich & Kwong, "An equation of State", Chem Rev., vol44, p233, 1949.
² Par Research Project NX-19. "Extension of Range of Super Compressibility Table", American Gas Association, 1962.

Steam

Calculations	Uses 1967 IFC Formulation (ASME) equations to calculate specific weight and enthalpy of steam
Types	Saturated and Superheated
Temperature Range	20°C (68°F) to 800°C (1472°F) (RTD has a more limited range)
Pressure Range	1 kPa abs (1 psia) to 100,000 kPa abs (10,000 psia)
Saturated Steam	When measuring saturated steam, it is possible to omit either the pressure or temperature sensor since, on the saturated line, there is a corresponding pressure for all temperatures

Important: Specifications are subject to change without notice.

Dimension Drawings

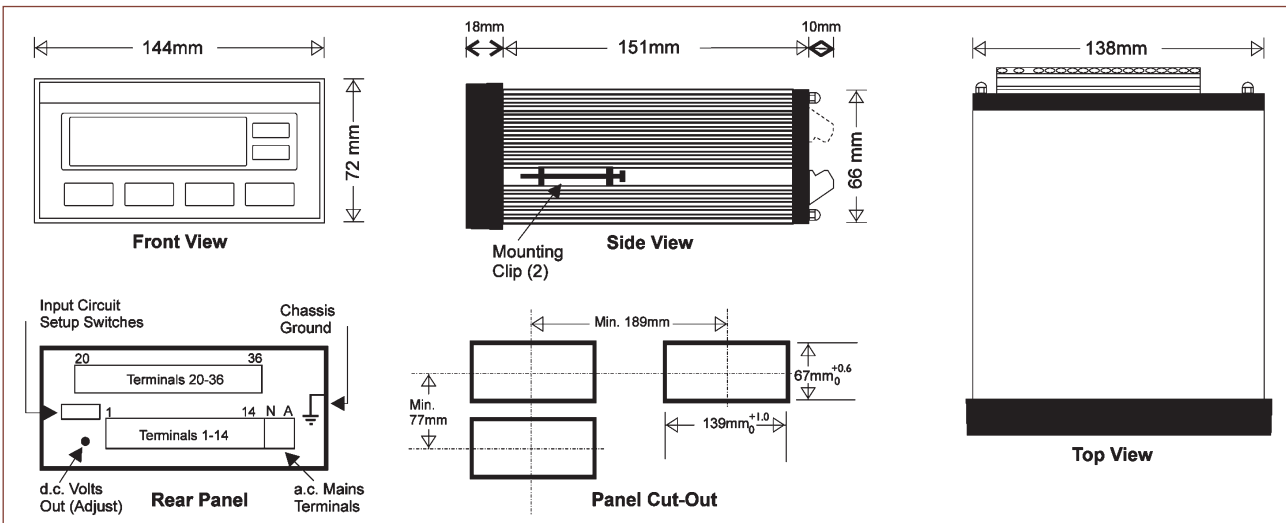

Terminal Descriptions Model 415

Terminals Common to all Models	415A	415R	RS232/422 Option	Isolated 4-20 mA Output Option	High & Low Relay Alarm Option
No. 1 Calibration	No. 3 Flow 1 (4-20mA)	No. 3 Flow 1 (4-20mA)	No. 20 RS232 Signal Ground	No. 20 Not Used	No. 31 High - Normally Open
No. 2 Switch Common	No. 4 Temp. (4-20mA)	No. 4 PT100 (+)	No. 21 RS232 Data In	No. 21 0 Volts	No. 32 High - Normally Closed
No. 11 DC Power Out	No. 5 Reset Switch	No. 5 PT100 Signal (+)	No. 22 RS232 Data Out	No. 22 0-10 Volts Out	No. 33 High - Common
No. 12 DC Ground	No. 6 Display Switch	No. 6 PT100 Signal (-)	No. 23 RS422 (-) Data Out	No. 23 -12 volts	No. 34 Low - Normally Open
No. 13 DC Power In	No. 7 Pressure (4-20mA)	No. 7 Pressure (4-20mA)	No. 24 RS422 (+) Data Out	No. 24 I (-)	No. 35 Low - Normally Closed
	No. 8 Flow Common	No. 8 Flow Common	No. 25 RS422 (-) Data In	No. 25 I (+)	No. 36 Low - Common
	No. 9 Flow Pulse Input	No. 9 Flow Pulse Input	No. 26 RS422 (+) Data In	No. 26 +15 Volts	
	No. 10 Pulse Out	No. 10 Pulse Out	No. 27 RS232 CTS	No. 27 Not Used	
	No. 14 Flow 2 (4-20mA)	No. 14 PT100 (-)			

Ordering Information

When specifying please indicate model(s) required using the following method.

415 R . 1 0 E C

Basic Model		
Temperature Input		
4-20mA	- A	
PT100 RTD	- R	
Mounting		
Panel	- 1	
Field	- N	
Explosionproof	- 3	

Special Options

- 0 - No option
- C - Conformal Coating
- G - German language version

Power Supply

- E - 240V ac
- A - 110V ac
- D - 14-28V dc
- J - 100V ac

Standard Options

- 0 - No options
- 1 - Isolated 4-20mA output
- 2 - RS232/422
- 3 - High/Low alarms
- 4 - 4-20mA and alarms
- 5 - RS232/422 and alarms