

# DIGITAL INDICATORS

## Model DN10



The DN-10 has been designed specifically to operate with strain gauge sensors such as Load cell, Pressure Transducer, LVDT, Etc.

- The setup sequence is simple and quick using 4 push buttons only.
- Calibration mode : real-weight (stand weight) or rated output (mv/v) from the sensor.
- Sampling speed : Appr. 100 times persecond
- Comparison function (Hi Lo)
- Small size
- DIN size: 72 x 72 x 11mm

## Dimensions

Unit : mm

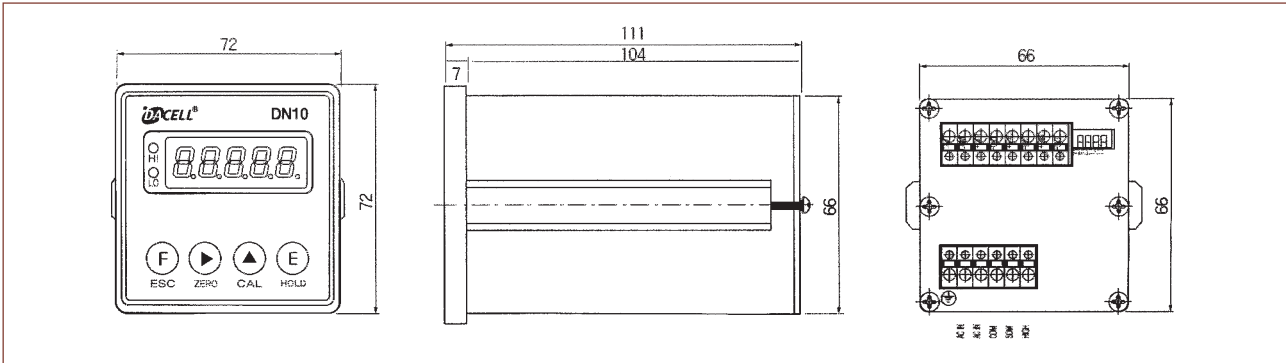

## Specifications

Specifications	Accuracy
Temperature Storage	-10°C to 85 °C
Temperature Operating	0°C to 60°C
Relay output	AC 250V 5A, DC 30V 5A
Transducer Excitation	10V DC
Type of Inputs Accepted	0~3mV/V
Transducer Current Drive	120mA
Calibration Method	Front Panel Switches
Temperature Drift	0.02% FS/°C
Sampling Speed	Appr. 100Times Per Second
Characters Displayed	5 Digits
Typical Accuracy	+/-0.02%
Polarity Indication	YES
Decimal Point Selection	Push button Setup
Resolution Maximum	±19999
Measured value display	7Segment %LED,height 10mm
Weight	800g
Mounting	Panel Mounting
Cutting size	66.5mm X 66.5mm
Power Requirements	AC110V/220V.50/60Hz
Output	DC 0 ~10V (DAC)
Relay out	Lo, Hi
Option	DC 4~20mA (DAC) RS232C, RS485



# DIGITAL INDICATORS

## Model DN-10W, DN-15W



The product have designed specifically to operate with strain gauge sensors such as Fast-measurement of Load cell, Pressure Transducer, LVDT, etc. The setup sequence is simple and quick using four push buttons only.

- High resolving power (16bit A/D)
- High precision (more than 0.012% F.S) and stability
- Quick sampling speed (100 times/sec)
- Built-in Shunt calibration switch
- Watch dog
- Small size (96 x 48 x 128mm), Cutting size : 92 x 45mm
- Weight : about 700g

### DN15W-Various Functions

- Calibration of actual load and sensor output value
- Peak hold and Sample hold
- Auto zero

### DN10W-Various Functions

- Calibration of actual load and sensor output value
- Peak hold and Sample hold
- Display part and analogue zero by auto zero (simultaneous zero of both digital display and analogue output)
- Upper and lower limit comparison output
  - Comparison output:
    - ON in case of Hi-set value  $\leq$  input value
    - ON in case of LO-set value  $\geq$  input value
  - Contact capacity : AC 250V 0.5A. DC 30V 0.5A
  - Relay life time : more than 200,000,000 times
- Analogue output : 0~10V or 4~20mA
- Option : RS232C (OP-01), RS485 (OP-02)

## Dimensions

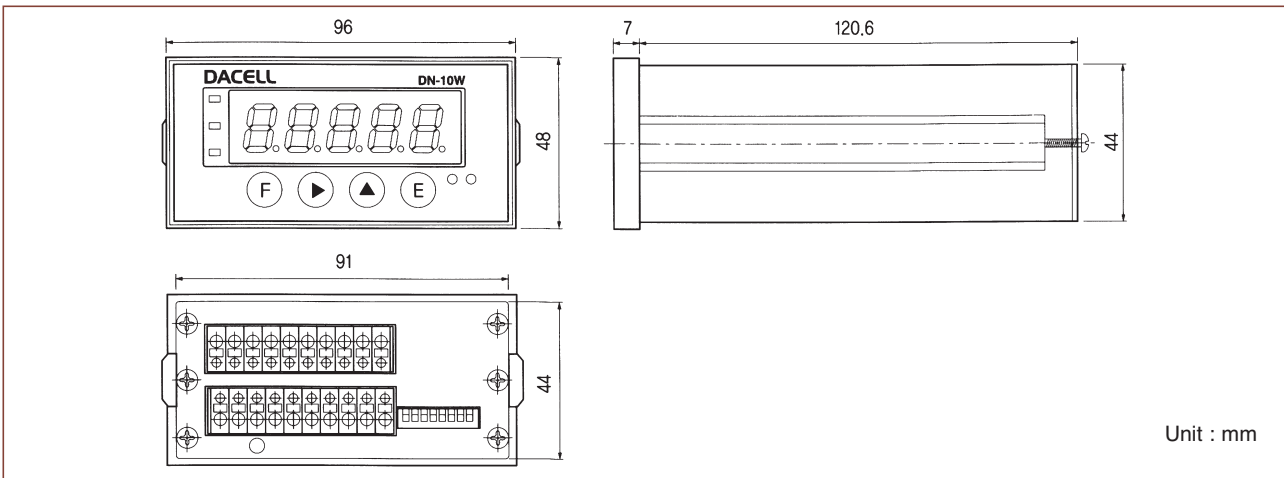

Unit : mm

## Specifications

Specifications	Accuracy
Application sensor	Strain guage sensor (350 $\Omega$ or 120 $\Omega$ )
Sensor authorized voltage (the number of Loadcell connection)	DC 5V, Loadcell (350 $\Omega$ ) available 4 DC 10V, Loadcell (120 $\Omega$ ) available 2
Zero adjustment range	100% F.S. (Auto Zero)
Input signal	1.0, 1.5, 2, 3mV/V (Dip switch)
Display	0000 ~ $\pm$ 19999
Display speed	Appox 30times/sec (Adjustment available by buff setting)
Character height	7Segment 14mm
Decimal point	Random setting available
Sampling speed	Max 100 times/sec
Zero variation	within 0.01%/°C (1mV/V)
Sensitivity variation	within 0.01%/°C
Voltage output	0 ~ 10V
Usage temperature range	-10°C ~ 60°C
Humidity	Less than 80% RH (no dew condensation)
Power source used	220V 50/60Hz (110V available by internal operation)