

AIR VELOCITY TRANSMITTERS FOR HVAC

EE65 Series

EE65 air velocity transmitter series are ideal for accurate ventilation control applications. They are operating on an innovative hot film anemometer principle.

The E+E thin film sensor guarantees very good accuracy at low air velocity, which is not possible for conventional anemometers with commercial temperature sensors or NTC bead thermistors.

Moreover, the E+E sensor is much more insensitive to duct and dirt than all other anemometer principles. This means high reliability and low maintenance costs.

EE65 series are available with current or voltage output, the measuring range and the response time can be selected with jumpers by the user.

Low angular dependence enables easy, cost-effective installation. An integrated LC display and a version with remote sensing probe are also available.



Typical Applications

- HVAC
- Process and environmental control

Features

- Low angular dependence
- Easy installation
- Adjustable to application requirements

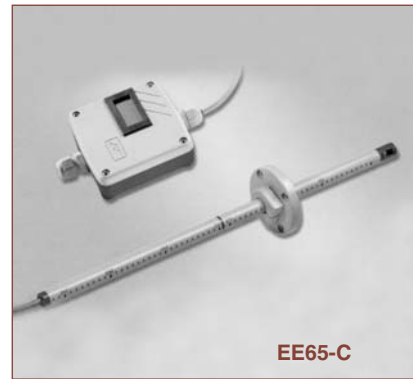

Technical Data EE65

Measuring Values

Working range ¹⁾	0... 10m/s (0...2000ft/min) 0...15m/s (0...3000ft/min) 0...20m/s (0...4000ft/min)	
Output ¹⁾	0 - 10 V 4 - 20 mA	-1mA < I _L < 1 mA R _L < 450Ω
Accuracy at 20°C (68°F) 45% RH and 1013 hPa	0... 10m/s (0...2000ft/min) 0...15m/s (0...3000ft/min) 0...20m/s (0...4000ft/min)	± (0.2m/s / 39.4ft/min + 3 % of M. V.) ± (0.2m/s / 39.4ft/min + 3 % of M. V.) ± (0.2m/s / 39.4ft/min + 3 % of M.V.)
Response time τ ₉₀ ^{1) 2)}	Typ. 4 sec. or typ. 0.2 sec.	(at constant temperature)

General

Power supply	SELV 24V AC/DC ± 20%	SELV = Safety Extra Low Voltage
Current consumption for AC supply for DC supply	max. 150mA max. 90 mA	
Angular dependence	< 3% of measurement at Δα < 10°	
Cable gland	M16x1.5	cable ø 4.5 - 10mm (0.18 - 0.39")
Electrical connection	Screw terminals max. 1.5mm ² (AWG16)	
Electromagnetic compatibility	EN 50081-1	CE
	EN 50082-1	
Housing / protecting class	Polycarbonate / IP65, Nema 4	with LC display: IP40
Temperature range	working temperature probe working temperature electronic storage temperature	-25...50°C (-13...122°F) -10...50°C (14...122°F) -30...60°C (-22...140°F)

¹⁾ Selectable by jumper.

²⁾ Response time τ₉₀ is measured from the beginning of a step change of air velocity to the moment of reaching 90% of the step.

AIR VELOCITY TRANSMITTERS FOR HVAC

Dimensions (mm)

1mm = 0.03937" / 1" = 25.4mm

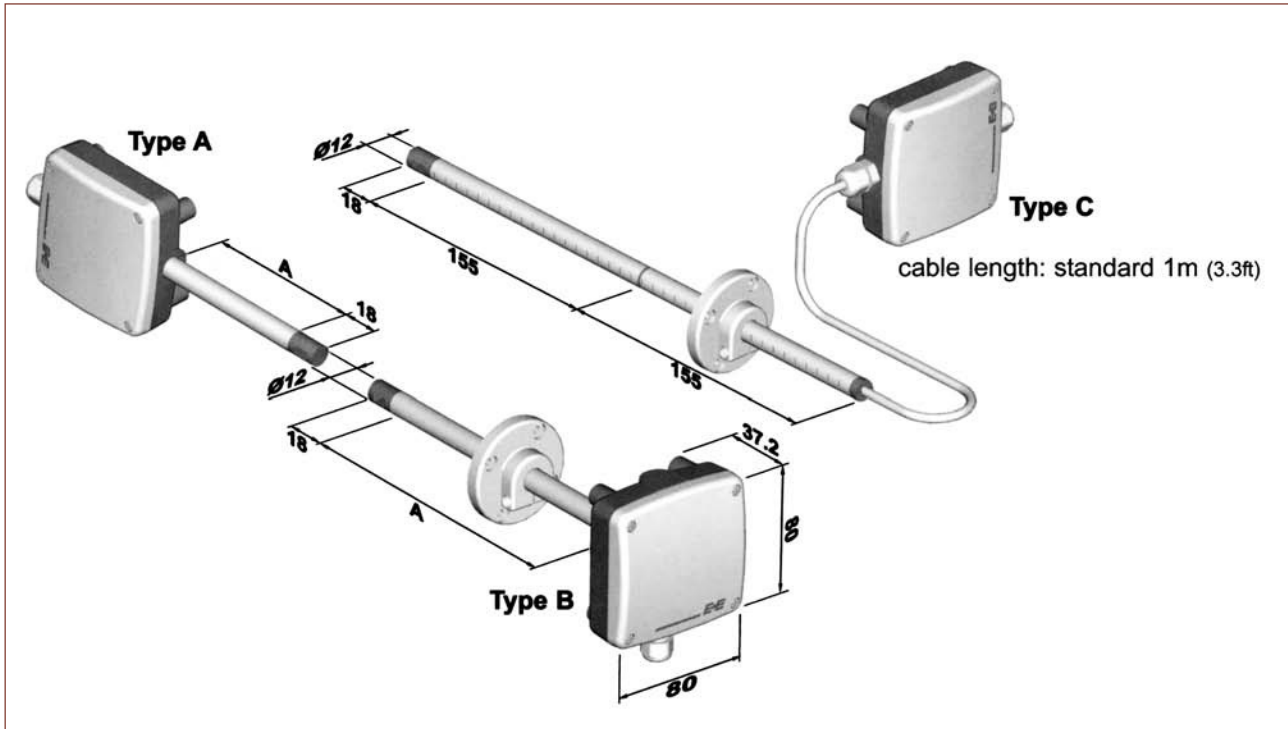

Air Velocity Measurements

TEST & MEASUREMENTS

Connect Diagram

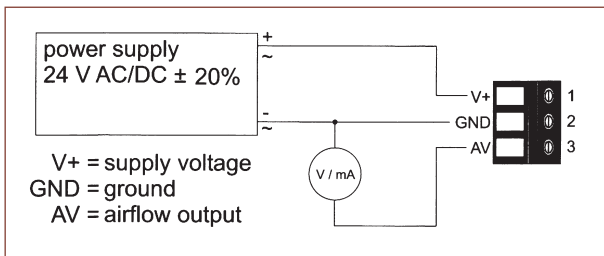

Order Example

EE65-VB5-D02
 Model: Velocity
 Housing: Duct mounting
 Probe Length: 200mm (7.9")
 Display: with LC display

Ordering Guide EE65

Model	Housing	Probe Length (according to "A")	Cable Length (Type C only)	Display
Velocity (V)	Wall mounting	(A) 100mm (3.9")	(3) 1m (3.3ft)	without display (no code)
	Duct mounting	(B) 200mm (7.9")	(5) 2m (6.6ft)	with display (D02)
	Remote sensor probe	(C) others	(X) 5m (16.4ft) 10m (32.8ft)	
EE65-				

