

HVAC ROOM TRANSMITTER FOR CO₂, RELATIVE HUMIDITY AND TEMPERATURE

EE80 Series

The EE80 series combines CO₂, relative humidity (RH) and temperature (T) measurement in one housing. The snap-in mounting concept stands for easy installation and replacement within seconds.

EE80 series set new standards in CO₂ measurements for HVAC. The operation is based on the infrared principle. A patented auto-calibration procedure compensates for the aging of the infrared source and ensure outstanding long term stability.

The basic EE80 version for CO₂ and T can be easily extended with a RH plug-in module. The well proven E+E sensor technology guarantees accurate and long term stability.

EE80 provides analogue voltage outputs. The optional display indicates sequentially the actual measuring data.



Typical Applications

- Building management for residential and office areas
- Ventilation control

Features

- CO₂ / RH / T measurement in one device
- RH output with plug-in module
- Easiest installation
- Modern design
- Long term stability
- Optional display

Technical Data EE80

Measuring Value

CO₂

Measurement principle	Non-Dispersive Infrared Technology (NDIR)	
Sensor	E+E Dual Source Infrared System	
Working range	0 - 2000ppm	0 - 5000ppm
Accuracy at 20°C (68°F) and 1013mbar	0...2000ppm: 0...5000ppm:	< ± (50ppm +2% of measuring value) < ± (50ppm +3% of measuring value)
Response time τ_{63}	< 90 sec	
Temperature dependence	typ. 2ppm CO ₂ /°C	
Long term stability	typ. 20ppm / year	
Sample rate	ca. 30.5 min	

Relative Humidity (only for versions with voltage output)

Measurement principle	capacitive	
Sensor element	HC103	
Working range ¹⁾	10...90% RH	
Accuracy at 20°C (68°F)	± 3% RH (30...70% RH)	± 5% RH (10...90% RH)

Temperature

Accuracy at 20°C (68°F)	±0.3°C (±0.54°F)	version with current output 4 - 20mA: ±0.7°C (±1.26°F)
-------------------------	------------------	--

Outputs

0...2000/5000ppm / 0...100% RH / 0...50°C (32...122°F)	0 - 5V 0 - 10V 4 - 20mA	-1mA < I _L < 1mA -1mA < I _L < 1mA RL < 500 Ohm
--	-------------------------------	--

General

Supply voltage SELV	24V AC ±20%	15 - 35V DC	SELV = Safety Extra Low Voltage
Power requirement	< 3W		
Warm up time ²⁾	< 5 min		
Display	LC display: alternating CO ₂ (ppm) / T (°C or °F) / RH (% RH)		
Electrical connection	Screw terminals max. 1.5mm ² (AWG16)		
Electromagnetic compatibility	EN 61000-6-3 EN 61000-6-1	EN61326-1+A1+A2:05.2002	
Working temperature range	0...95% RH (non condensing) / -5...55°C (23...131°F)		
Storage temperature range	0...95% RH (non condensing) / -20...60°C (-4...140°F)		

¹⁾ refer to the working range of the humidity sensor HC103!

²⁾ Warm up time for performance according specification.

HVAC ROOM TRANSMITTER FOR CO₂, RELATIVE HUMIDITY AND TEMPERATURE

Connection Diagram

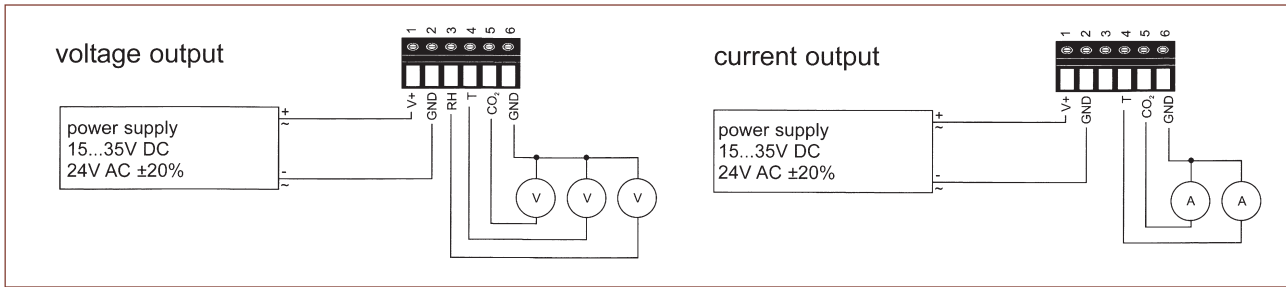

Housing Dimensions (mm)

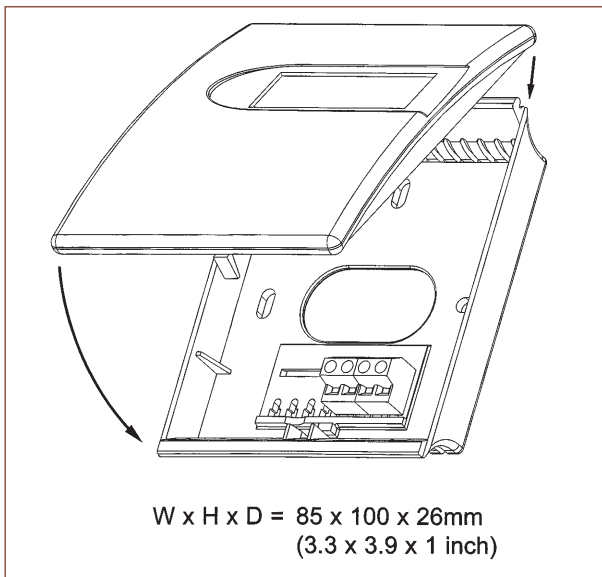

Material of housing: PC
Protection class: IP20

Colour of housing: Cover: RAL 9003 (signal white)
Back: RAL 7035 (light grey)

(other colours upon request)

Order Example

EE80-2CT3D04

Version with voltage output:

Working range: 0...2000ppm
Model: CO₂ + Temperature
Output: 0 - 10V
Display: with display
T-Unit: °C
T-Scale: 0...50°C (32...122°F)

Ordering Guide EE80

Version with voltage output:

Working Range	Model	Output	Display	T-Unit	T-Scale
0...2000ppm (2)	CO ₂ + T (CT)	0-5V (2)	without display (--)	°C (--)	standard (0...50°C) (32...122°F) (--)
0...5000ppm (5)	CO ₂ + T + RH (CTF)	0-10V (3)	with display (D04)	°F (E01)	other T-scaling refer to page 11 (Txx)
EE80-					

Version with current output:

Working Range	Model	Output	Display	T-Unit	T-Scale
0...2000ppm (2)	CO ₂ + T (CT)	4-20mA (6)	without display (--)	°C (--)	standard (0...50°C) (32...122°F) (--)
0...5000ppm (5)			with display (D04)	°F (E01)	other T-scaling, please contact us (Txx)
EE80-					

Accessories

- humidity plug-in module

