

ROTARY ENCODERS

TRD-S / SH Series Incremental Encoder



Features

- Small body with 38 mm diameter and 30 mm depth
- Although compact, lineup reaches 2,500 P/R
- Low cost contributes to system cost-effectiveness

List of Model Numbers

Type	Appearance	Model Number	Source Voltage	Output	Output Type	Pulse / Revolution	
Shaft		TRD-S□A	4.5 to 13.2 VDC	2-phase with home position in reverse operation □□	Open collector output	* 10, 20, 30, 40, 50, 60, 100, 200, 250, 300, 360, 400, 500, 600, 800, 1000, 1024, 1200, 2000, 2500	
		TRD-S□B	10.8 to 26.4 VDC		Open collector output		
		TRD-S□V	4.75 to 5.25 VDC	2-phase with home position in forward operation □□	Line driver output		
Hollow shaft		TRD-SH□A	4.5 to 13.2 VDC	2-phase with home position in reverse operation □□	Open collector output		* 10 to 60: Open collector output only.
		TRD-SH□B	10.8 to 26.4 VDC		Open collector output		
		TRD-SH□V	4.75 to 5.25 VDC	2-phase with home position in forward operation □□	Line driver output		

Model Numbering System

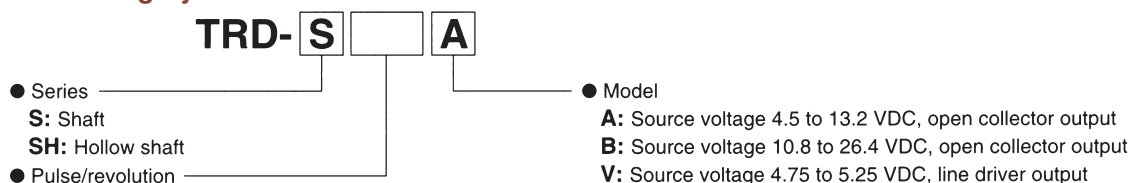

Pulse and Frequencies

Pulse / Revolution	10	20	30	40	50	60	100	200	250	300	360	400	500	512	600	800	1000	1024	2000	2500	
Max. response frequency (kHz)*	1	2	3	4	5	6	10	20	25	30	36	40	50	50	60	80	100	100	200	200	
Applicable models	TRD-S□A/TRD-SH□A	●	●	●	●	●	●	●	●	●	●	●	●	●	●	●	●	●	●	●	●
	TRD-S□B/TRD-SH□B	●	●	●	●	●	●	●	●	●	●	●	●	●	●	●	●	●	●	●	●
	TRD-S□V/TRD-SH□V							●	●	●	●	●	●	●	●	●	●	●	●	●	●

* Maximum response frequency is defined by the the following formula : Maximum revolution speed = (Maximum response frequency / Pulse) x 60
 * The encoder does not respond to revolution faster than the maximum speed.

Electrical Specifications

Model		TRD-S□A/TRD-SH□A	TRD-S□B/TRD-SH□B	TRD-S□V/TRD-SH□V	
Power source	Power source voltage	4.5 to 13.2 VDC	10.8 to 26.4 VDC	4.75 to 5.25 VDC	
	Allowable ripple	3% rms max.		-	
	Current consumption	50 mA max.		50 mA max.	
Signal waveform		Two-phase + home position		Two-phase + home position	
Maximum response frequency		200 kHz		200 kHz	
Duty ratio		50 ±25%		50 ±25%	
Phase difference with		25 ±12.5%		25 ±12.5%	
Signal width at home position		100 ±50%		100 ±50%	
Output	Rise / Fall time	1 μs max. (when cable length is 1m)		-	
	Output type	NPN open collector output		Liner-driver *	
	Output logic	Negative logic (active low)		Positive logic (active high)	
	Output voltage	"H"	-		2.5 V min.
		"L"	0.4 V max.		0.5 V max.
	Influx current	30 mA max.		-	
Load power voltage	30 VDC max.		-		

* Equivalent to 26C31, lever is equivalent to 26C32.

ROTARY ENCODERS

TRD-S / SH Series

Mechanical Specifications

Initial torque	0.001N·m (+20°C) max.
Moment of inertia	0.3 x 10kg ² ·m ²
Allowable load	Radial: 20N
	Thrust: 10N
Maximum allowable speed (Note 1)	6000 rpm
Cable	External diameter ø5 mm
	5-wire oil-proof shielded vinyl chloride cable
	Nominal section area of core: 0.14 mm ² (Line driver output: 8 cores, 0.14 mm ²)
Weight	Approx. 100g

Environmental Requirements

Ambient temperature	-10 to +70°C
Storage temperature	-25 to +85°C
Operating humidity	35 to 85% RH (with no condensation)
Withstand voltage	500 VAC (50 Hz/60Hz) for one minute
Insulation resistance	50 MΩ min.
Vibration resistance	Durable for 1 hour along 3 axes at 10 to 55 Hz with 0.75mm amplitude
Shock resistance	11 ms with 490 m/s ² applied 3 times along 3 axes
Protection	Simple dust protection: IP40

Output Signal Timing Chart

TRD-S□A/TRD-S□H□A
TRD-S□B/TRD-S□H□B

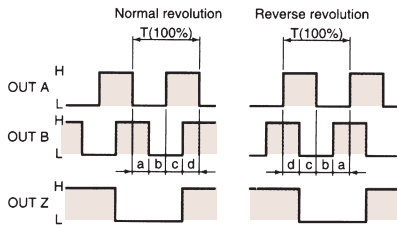

TRD-S□V/TRD-S□H□V

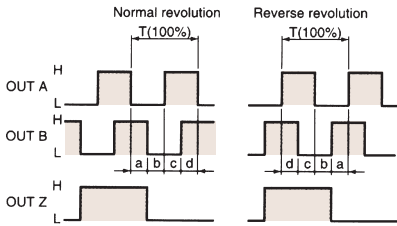

a, b, c, d = 1/4T ± 1/8T

*"Normal" means clockwise revolution viewed from the shaft.

Open Collector Output Circuit

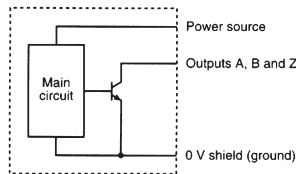

Open Collector Connections

Shielded cable is not connected to the encoder body.

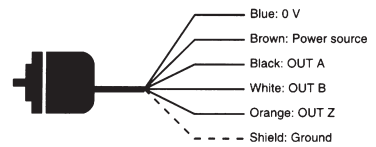

Line Driver Output Circuit

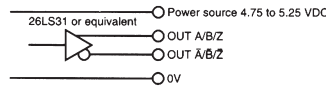

- The line driver can use a RS-422A compliant twisted pair cable of up to 1,200 m.

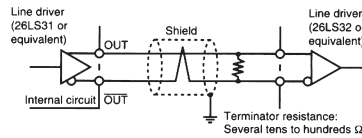

- Output signal turns to "H" level when the cable or connector is disconnected.

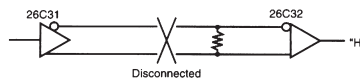

Line Driver Connections

Shielded cable is not connected to the encoder body.

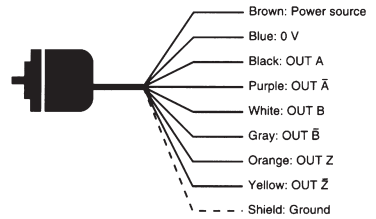

External Dimensions

TRD-S□A/TRD-S□B/TRD-S□V

TRD-S□H□A/TRD-S□H□B/TRD-S□H□V

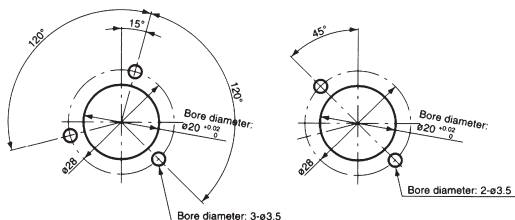
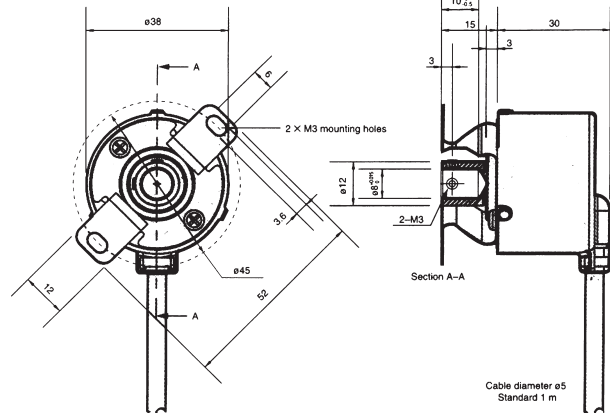
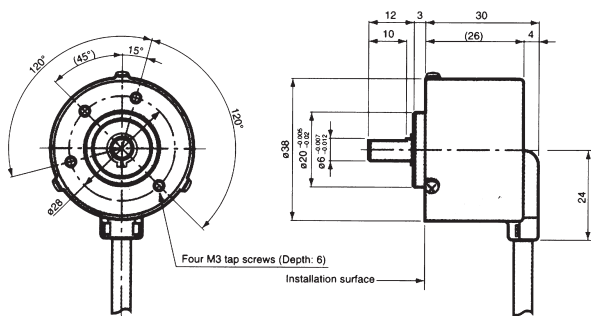

Mounting hole panel cutout (3 holes)

Mounting hole panel cutout (2 holes)

